

CSP-3222 TWIC ENTRY INTERSECTION TRAFFIC SIGNAL AT BARBOURS CUT TERMINAL

Pre-Proposal Meeting
June 3, 2024
9:00 a.m.

PORT HOUSTON



PORT HOUSTON

AGENDA

1. Pre-Proposal Meeting House Rules
2. Introductions
3. Business Equity
4. Procurement Services
5. Selection Criteria
6. Project Scope
7. Questions



PRE-PROPOSAL MEETING HOUSE RULES

- Attendees will begin the meeting in listen-only mode.
- There will be a Q&A session at the end of today's presentation.
- If you have any questions during the presentation, you may submit your Questions through the Teams Chat feature and they will be addressed at the end of the presentation.
- This presentation recording will be posted on the BuySpeed homepage under "Pre-Bid/Proposal Conference Information."



PHA PERSONNEL

- Roger Hoh– Director, Project and Construction Management
- Godly Sunny – Project Manager
- Yvette Camel-Smith – Director, Procurement
- Tanika Chukwumerije – Manager Contracts, Procurement
- Alexis King– Contract Administrator, Procurement
- Dr. Sabeeta Bidasie-Singh - Director, Business Equity
- Brenda Ruiz – Business Equity Supplier Diversity Manager
- Eduardo Mejia – Compliance Analyst, Business Equity



PORT COMMISSION



Ric Campo
Chairman of the Port Commission



Dean E. Corgey
Commissioner



Clyde Fitzgerald
Commissioner



Stephen H. DonCarlos
Commissioner



Wendy Montoya Cloonan
Commissioner



Alan Robb
Commissioner



Thomas Jones, Jr.
Commissioner

Harris County Wage Rate Compliance & Requirements:

- Attendance at pre-bid/proposal meetings and preliminary meetings
- Review and approve weekly certified payroll records
- Monitor wage rate compliance
- Review claims of non-compliance from the field and recommend appropriate responses as required or permitted under the Wage Scale Act



BUSINESS EQUITY



PORT HOUSTON

BUSINESS EQUITY S/MWBE INITIATIVE

- Business Equity Division provides resources to small, minority- and woman-owned businesses (S/MWBE) seeking to participate in Port Houston procurements and contracts.
- Port Houston promotes business opportunities for all sectors of the community and recognizes the importance of vendor and supplier diversity in its contracts.
- Port Houston has established an organizational 35% Small Business participation goal and a 30% Minority- and Woman Business Enterprise (MWBE) aspirational goal.

35%

SBE participation
goal

30%

MWBE aspirational
goal



PORT HOUSTON

BUSINESS ENTERPRISE DEFINITIONS

Small Business Enterprise (SBE)

- Gross revenues or number of employees, averaged over the past three years does not exceed the size standards defined by SBA.
- The net worth of the owner must be less than \$2.047 million, excluding the owner's primary residence and assets of the business.

Minority Business Enterprise (MBE)

- At least 51% Owned by one or more Minority Individuals, or at least 51% of the equity is Owned by one or more Minority Individuals.
- Both the management and daily business operations are carried out and controlled by one or more of the Minority Individuals who own it.

Woman-Owned Business Enterprise (WBE)

- At least 51% Owned by one or more Women, or at least 51% of the equity is Owned by one or more Women
- Both the management and daily business operations are carried out and controlled by one or more of the Women who own it.



CERTIFYING PARTNERS

- City of Houston *
- Houston Minority Supplier Development Council
- METRO *
- National Minority Supplier Development Council & Affiliates
- Small Business Administration 8(a) *
- South Central Texas Regional Certification Agency – SCTRCA *
- Texas Comptroller of Public Accounts – HUB Certification
- Texas Department of Transportation – TxDOT *
- Women’s Business Enterprise Alliance
- Women’s Business Enterprise National Council & Affiliates – WBENC

* No fee to apply



PORT HOUSTON S/MWBE ENROLLMENT DIRECTORY

How do I identify Port Houston enrolled small, minority- and woman-owned businesses (S/MWBE)?

Search for businesses in 2 easy steps:

1. Visit <https://porthouston.smwbe.com> Under the section on the left labeled Small, Minority and Woman Owned Business Directory and Online Application select the blue button labeled, **"Find a S/MWBE Firm"**.

2. You will need to complete at least one of the fields in the popup window titled, Port Houston S/MWBE Enrollment Directory and Search.

PORT HOUSTON
THE INTERNATIONAL PORT OF TEXAS™

OUR MAIN SITE CONTACTS AND SUPPORT

PORT HOUSTON
BUSINESS EQUITY
COMPLIANCE SYSTEM

Log In

SMALL, MINORITY AND WOMAN OWNED BUSINESS DIRECTORY AND ONLINE APPLICATION

Search for small, minority, and woman-owned businesses enrolled in Port Houston's Business Equity Programs, and/or apply to become an enrolled small, minority or woman-owned business.

Find a SMWBE Firm

OUTREACH & PROGRAM NOTICES

Business Networking Events

Detailed Description

RSVP For An Event

SYSTEM TRAINING

www.porthouston.smwbe.com



TIPS TO INCREASE S/MWBE PARTICIPATION

- Establish relationships with S/MWBEs in advance
- Use the Port of Houston Directory.
- Advertise opportunities
- Offer assistance and use the services and assistance, as appropriate, of such organizations as the Small Business Administration and the Minority Business Development Agency of the Department of Commerce.
- What subcontractor's have you done business in the past and do they qualify?



BUSINESS EQUITY CONTRACT REQUIREMENTS

- 20% Small Business Enterprise (SBE) participation, 10 points relative weight



PROCUREMENT



PORT HOUSTON

PROCUREMENT

- No Contact Period – No communication between interested vendors and Port Houston staff during the active period
 - Technical questions should be submitted via BuySpeed
 - Last day to submit questions: 7 days before due date (6/11/2024)
- Responses are due no later than 11 a.m. on 6/18/2024
- Proposals must be submitted electronically via email to: **procurementproposals@porthouston.com**
- Bid bond-5% Total Amount Bid
- Nondivisible Procurement
- Use forms in the package
- Anticipated award date: 7/22/2024



EVALUATION CRITERIA

Port Houston will select the provider of the services offering the best value to Port Houston. The criteria and relative weights that will be considered by Port Houston in evaluating each Response are as follows:

Evaluation Criteria	Relative Weight (%)
Price	35
Reputation, Quality, Safety, and Environmental Record	30
Benefit to Port Authority	20
Overall Compliance with Port Authority Policies	5
Small Business Participation	10



SCOPE OF WORK OVERVIEW



PORT HOUSTON

Project Scope

Location Overview

- The location of this project is the intersection of the East Barbours Cut Boulevard with the TWIC Entrance Gate at the Barbours Cut Container Terminal.
- High Level Scope – Demo Paving, Repaving, Boring, Driller Shafts, Boring, Signal Pole Installation, Striping & Traffic Control Signs, Electrical & Communication, Fire Hydrant Relocation.
- Contractor's Laydown Area has been earmarked, along with the associated parking.
- Special Attention to Special Conditions : Milestone 1

7. Sequence of Operations and Access to Work:

- Contractor shall co-ordinate with Port Security personnel, Port Construction Representative, and Port Operations Representative in planning day-time and night-time work and any associated access needed to the Barbours Cut Terminal TWIC Entry Gate. The associated Traffic Controls Plans have been provided as a guideline, contractor will actively co-ordinate and update the aforementioned personnel regarding planned work 7 days in advance.
- For any work that must occur beyond standard working hours or extended hours, contractor must co-ordinate with Port Construction representative and provide a 3-day notice.
- There are no active gate operations on Saturdays and Sundays, however for any planned weekend work contractor shall provide a 3-day notice to the Port Construction representative and shall comply with contract limits for noise.

Milestone 1 consists of the following Work:

Contractor will submit all shop drawings & product submittals associated with Traffic Signal Poles, Mast-Arms, Controller and all other signal components within 21 days of PHA NTP and shall procure all Traffic Signal Poles and Traffic Signal Mast-Arms which are deemed long lead by the contractor needed for the complete functioning of the traffic signals within 45 days of NTP. No claims or change orders will be made in lieu of this milestone.

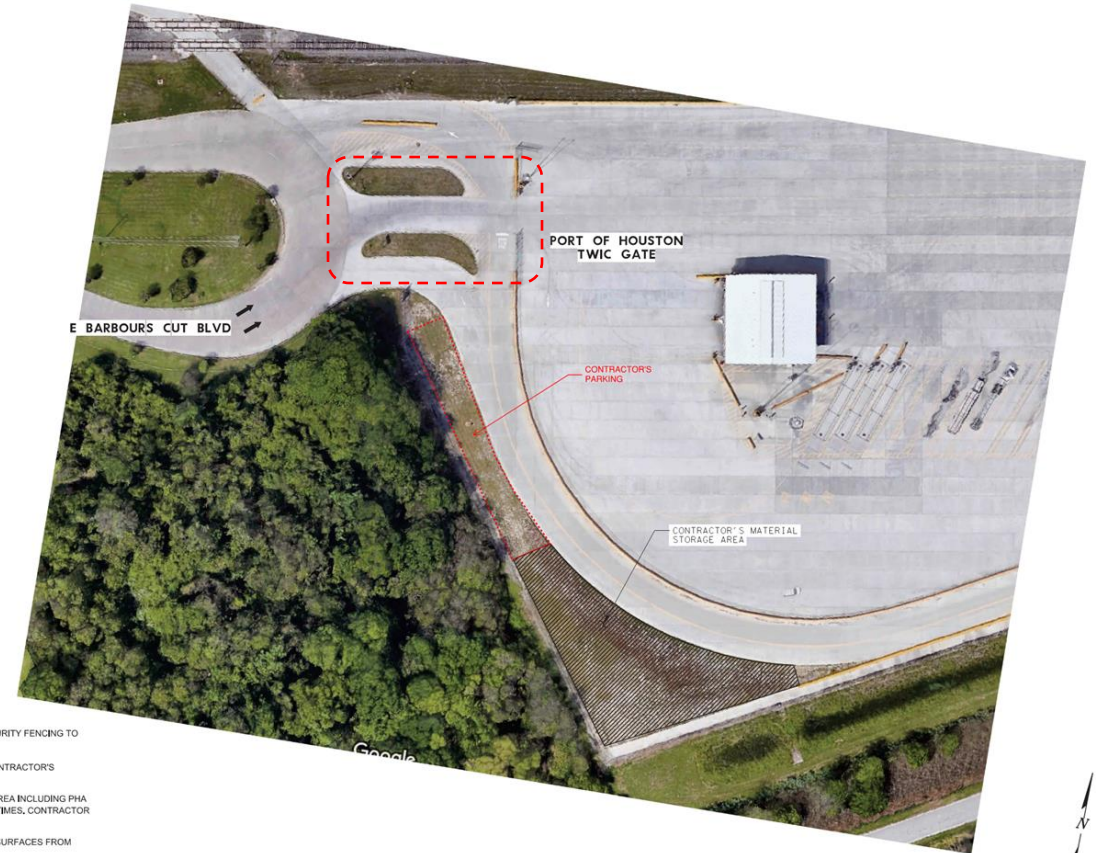

NOTES:

1. CONTRACTOR IS RESPONSIBLE TO PROVIDE TEMPORARY SECURITY FENCING TO ENCLOSE THE LAYDOWN/MATERIAL STORAGE AREA.
2. CONTRACTOR TO MOUNT A SIGN ON GATE FOR ACCESS TO CONTRACTOR'S LAYDOWN AREA.
3. CONTRACTOR SHALL ALLOW PHA ACCESS TO THE LAYDOWN AREA INCLUDING PHA OPERATIONS AND PHA ENGINEER'S REPRESENTATIVE. AT ALL TIMES, CONTRACTOR TO PROVIDE LOCK FOR MULTIPLE ACCESS.
4. CONTRACTOR SHALL PROTECT PAVED ROADWAY AND PAVED SURFACES FROM DAMAGE.
5. CONTRACTOR TO PERFORM DAILY CLEANUP OF PUBLIC AREAS AFFECTED BY CONSTRUCTION AND CONSTRUCTION TRAFFIC, INCLUDING SWEEPING AND DUST CONTROL, AS NEEDED.
6. EXERCISE CAUTION, FOR HEAVY TRUCK TRAFFIC ENTERING EXISTING GATE, CONTRACTOR SHALL COORDINATE WITH PHA CONSTRUCTION REPRESENTATIVE FOR SCHEDULED WORK AND DELIVERIES ACCORDINGLY.
7. DUE TO THE SHORT DURATION OF PROJECT, A CONSTRUCTION TRAILER IS NOT REQUIRED BY PHA, IF CONTRACTOR WOULD LIKE TO PROVIDE ONE AT HIS OWN EXPENSE, A REQUEST SHALL BE MADE TO PORT CONSTRUCTION REPRESENTATIVE TO DETERMINE IF AND WHERE SPACE MAY BE AVAILABLE AND WHAT UTILITIES ARE AVAILABLE.

Scope

Sequencing – Step 2-Weekend Operation

- Placement of traffic control/handling devices and signs.
- Install signal pole drilled shafts.
- Bore North-South Signal Conduit.

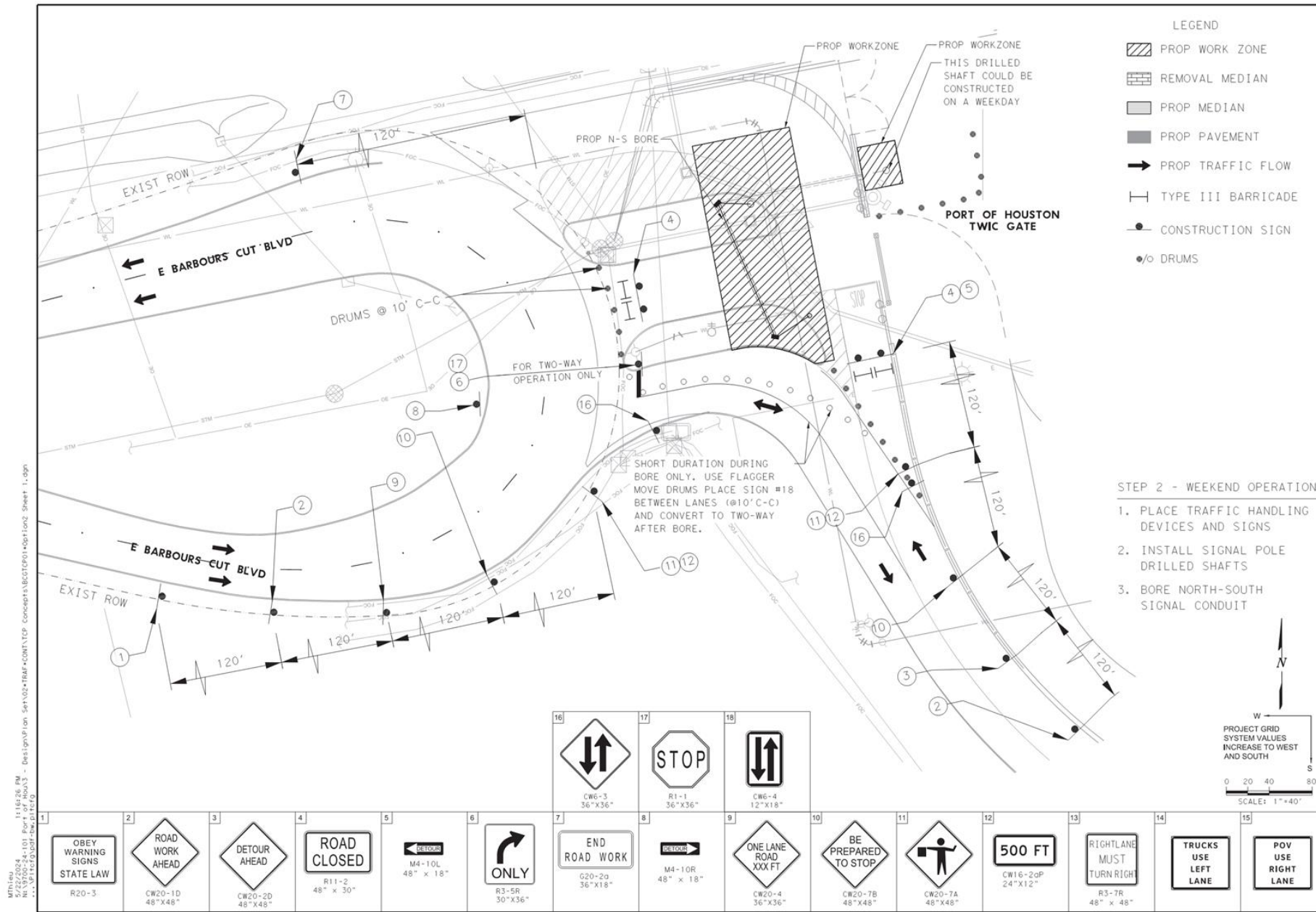

Scope

Sequencing – Step 4- Weekend Operation

- Placement of traffic control/handling devices and signs.
- Pour Pavement and Curb at the North and South Median islands and inside TWIC gate.
- Same or next weekend replace cantilever gate.
- See Step 5A and 5B for traffic handling devices and signs between weekends until step 4 work is completed.

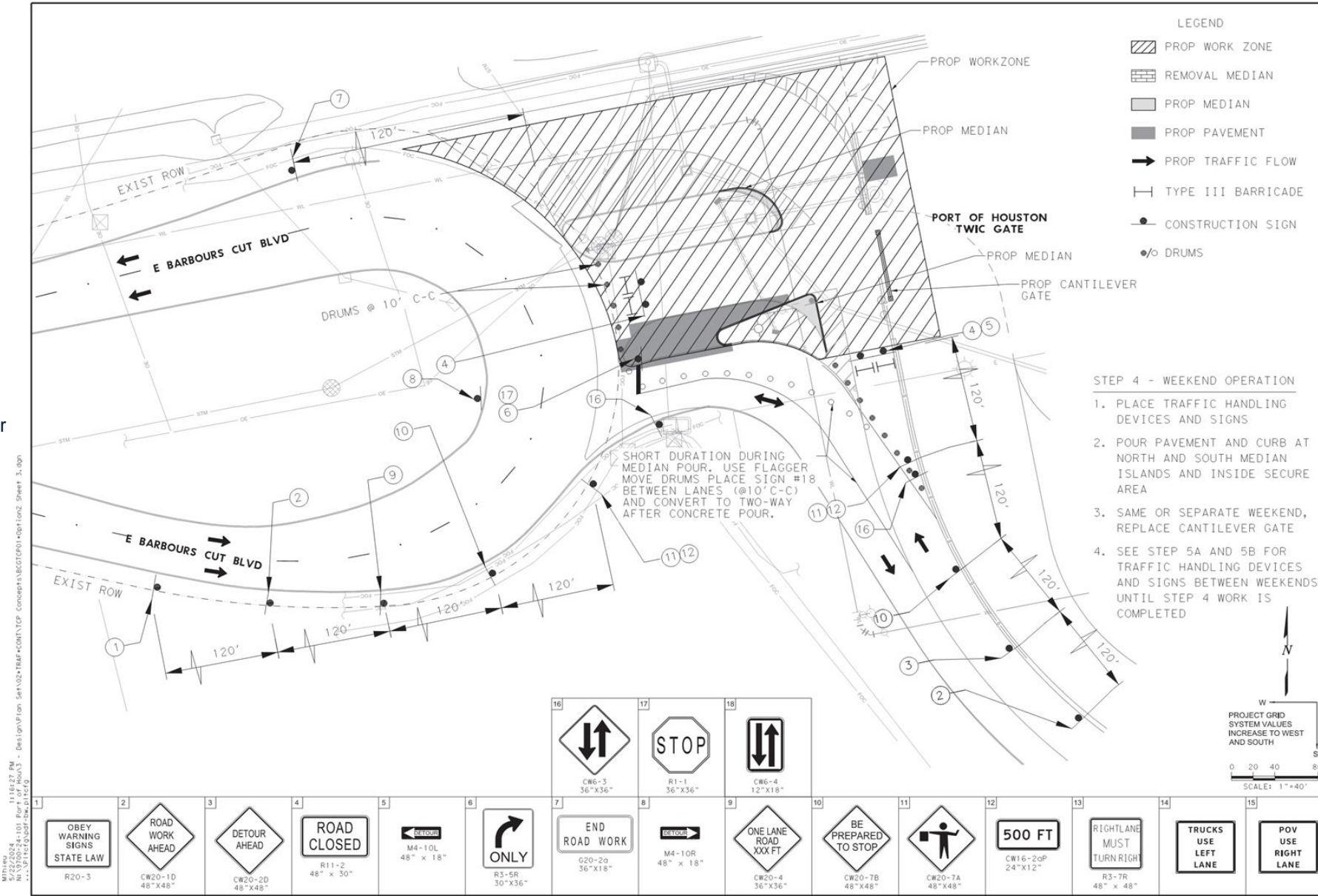

Scope

Sequencing – Step 5A-Weekday Operation

- Placement of traffic control/handling devices and signs.
- Install signal controller base and cabinet

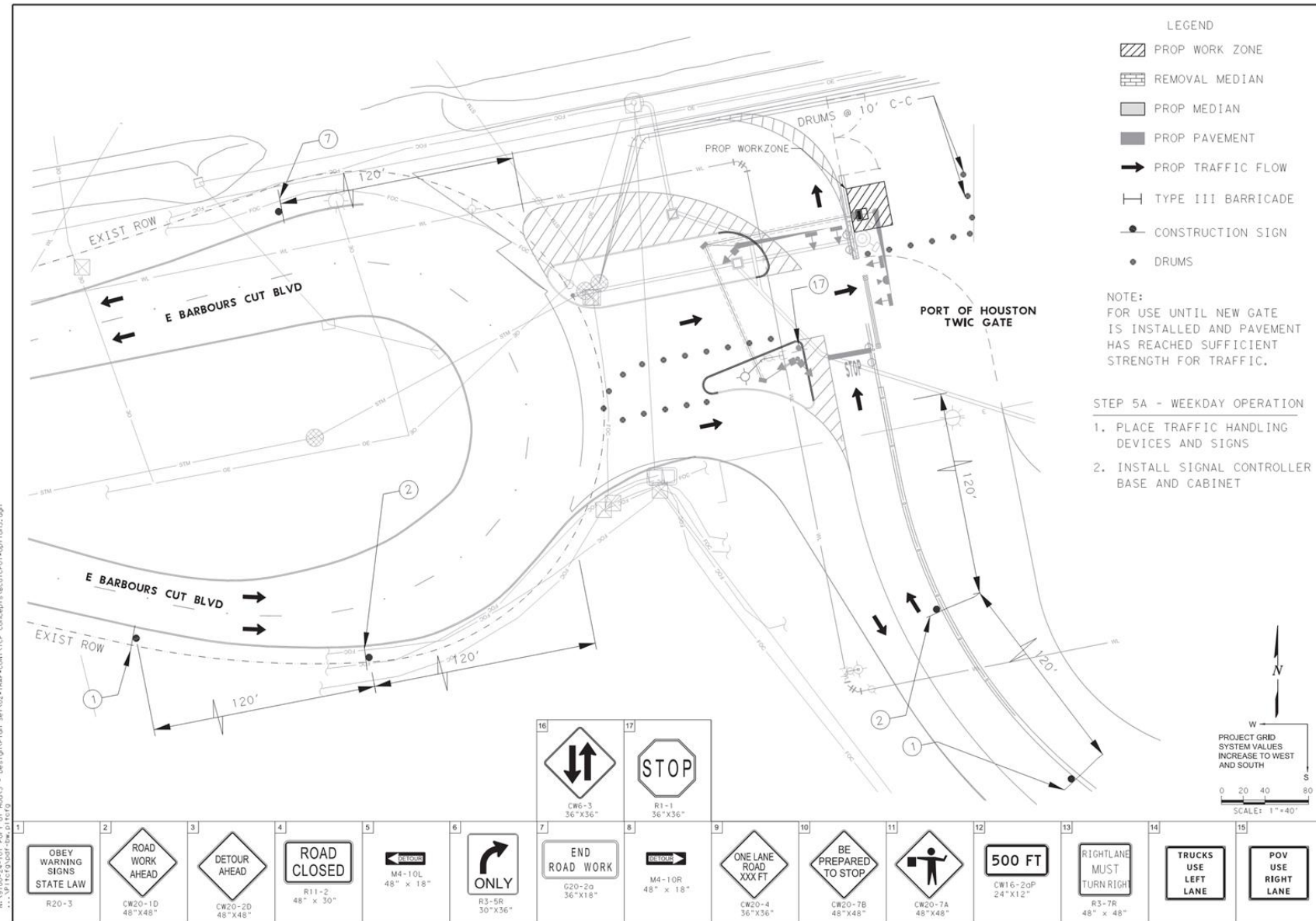

PORT HOUSTON

Scope

Sequencing – Step 6-Weekend Operation

- Placement of traffic control/handling devices and signs.
- Same or separate weekend, install all 3 signal poles, mast-arms and signal heads

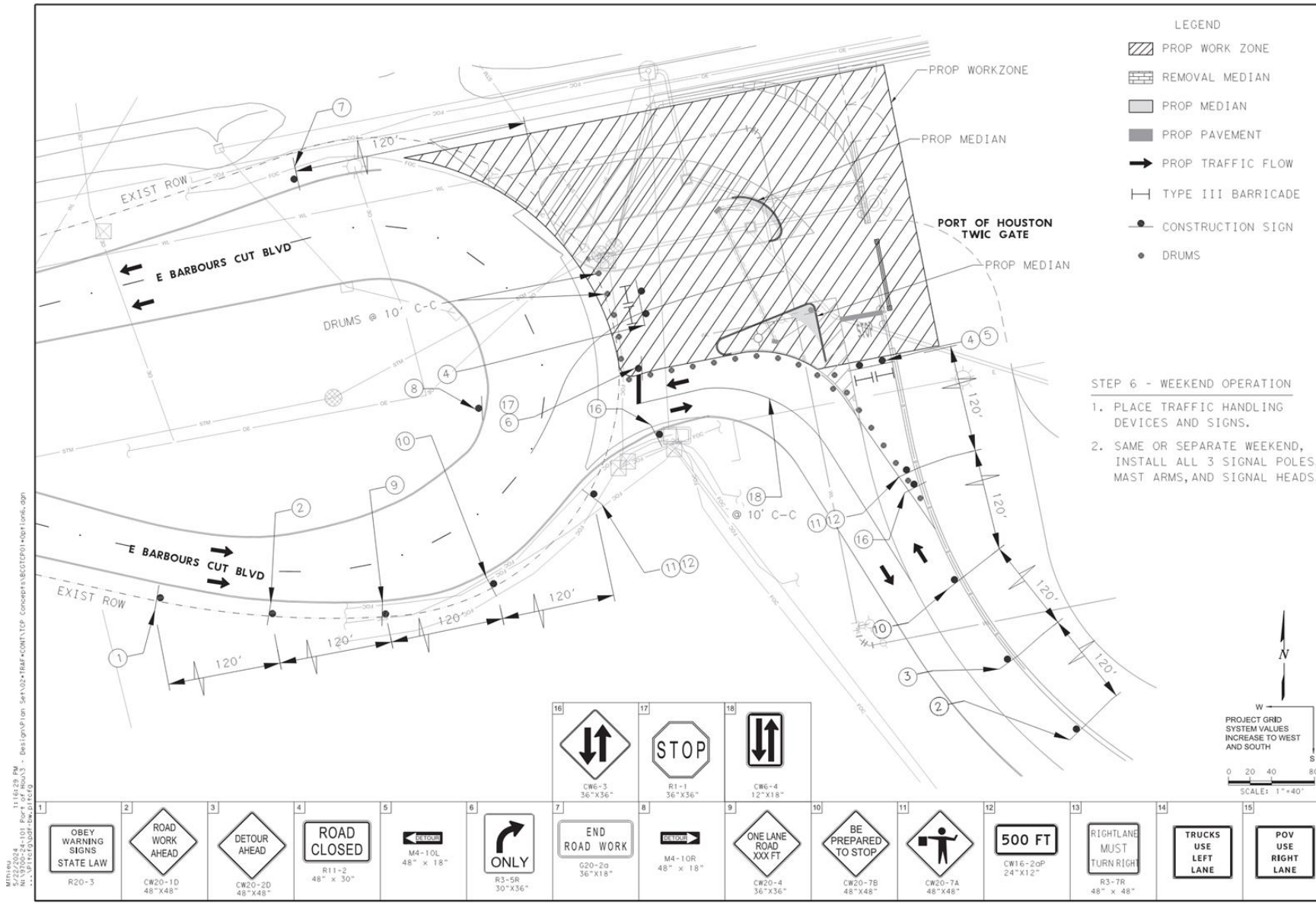

PORT HOUSTON

Scope

Sequencing – Step 7- Weekday Operation

- Placement of traffic control/handling devices and signs.
- Pull wiring and complete signal connections.
- Coordinate with PHA & EOR for signal programming, testing on weekends.
- Install permanent striping on weekend when signal is setup

21. Project Specific Special Conditions:

- Port Houston understands the extensive lead times that can be associated with certain traffic signal items. Upon market research the traffic poles and mast arms may have the longest lead time of the traffic signal components. In the event the required traffic signal poles and mast arms and installation of the same is the last task to complete, PHA would require the contractor to complete the available work within the contract period. The contractor would be required to remobilize at no additional cost and complete the installation of the planned traffic signal poles, mast arms and items associated with full functioning of the traffic signal when available. Retainage will not be released until all the traffic signals are installed and in-place per project specifications and drawings.
- Traffic Signal components should be one of the first submittals turned in for review. This is to accommodate for long lead items. PHA has added these items to the list of payment for unincorporated materials to accelerate this phase.
- Traffic Signal Control Software** – Contractor will provide GLANCE® Smart City Supervisory System by Applied Information or an equivalent cloud-based traffic control system. Contractor will provide submittals for the cloud-based traffic control software for approval to the Port

Special Conditions to Long-Form General Conditions
Form Revision Date: February 13, 2023

Page 10 of 11

TWIC ENTRY INTERSECTION TRAFFIC SIGNAL AT BARBOURS CUT TERMINAL MAY 2024

Authority and its Engineer of Record within 21 days of Notice to Proceed. Contractor shall consult with the Port Construction Representative and Engineer of Record for alternate cloud-based platforms before purchase of the same, at no additional cost to the Port Authority. Contractor, in coordination with its approved vendor, shall perform the software integration with the traffic controller, provide a plan for programming the signal, perform the initial programming and the final programming of the signal. Contractor and its vendor will perform any trouble-shooting required by Port Operations for the smooth and safe functioning of the signal prior to the completion of Contract.

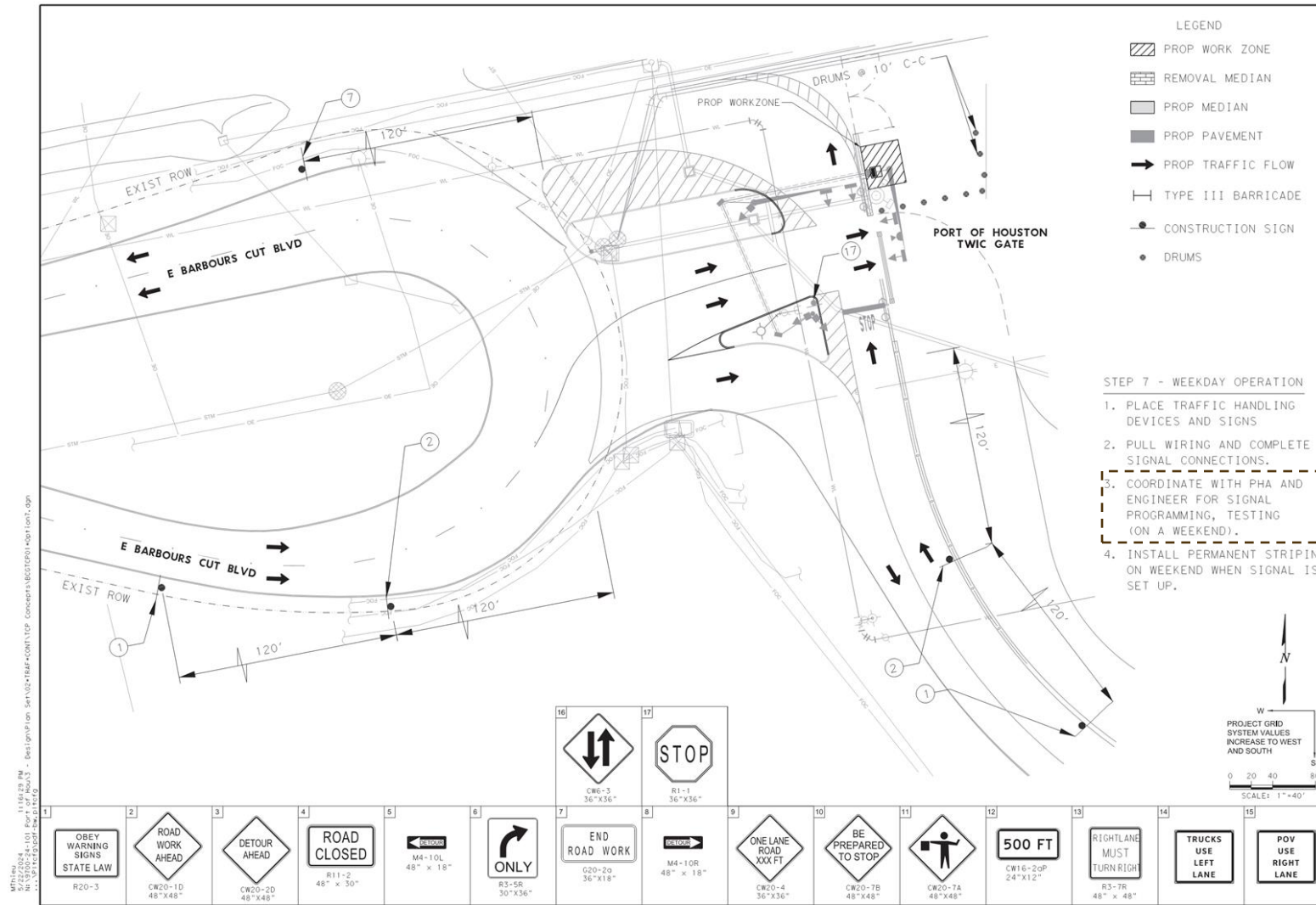

Scope

Electrical and Communication

- Power and Communication connections from existing HMP power and communication panel to the signaling cabinet.

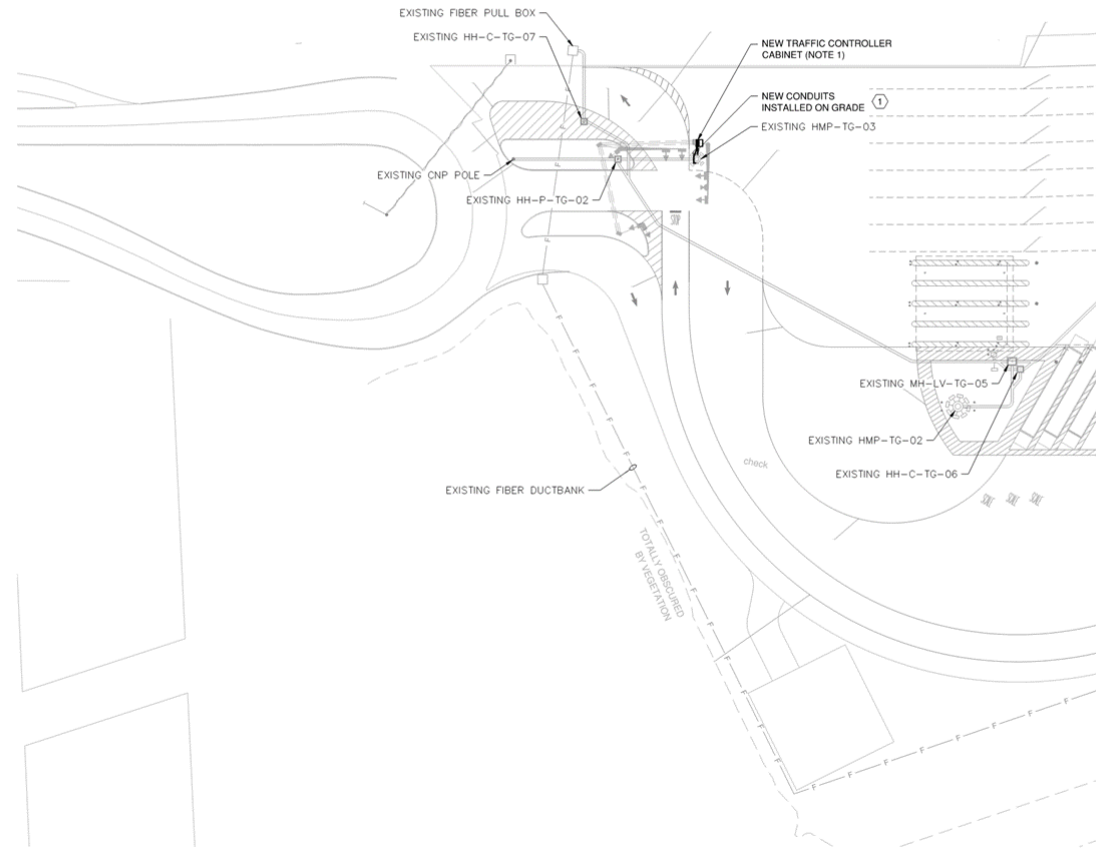

GENERAL NOTE:
1. REFER TO CIVIL DRAWINGS FOR TRAFFIC CONTROLLER CABINET INFORMATION AND INSTALLATION DETAILS.

KEYED NOTES:

- (1) INSTALL 1-1" CONDUIT FOR POWER ROUTED FROM NEW TRAFFIC CONTROLLER CABINET TO EXISTING CCTV/RDT POWER PANEL AND 1-1" CONDUIT FOR COMMUNICATIONS ROUTED FROM NEW TRAFFIC CONTROLLER CABINET TO EXISTING CCTV/RDT COMMUNICATIONS PANEL. CONDUIT TO BE INSTALLED ABOVE GRADE.

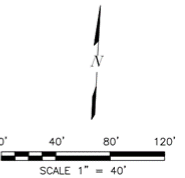

Scope

TWIC Entry Gate Replacement

- 33' feet sliding gate to replace existing 30' gate.

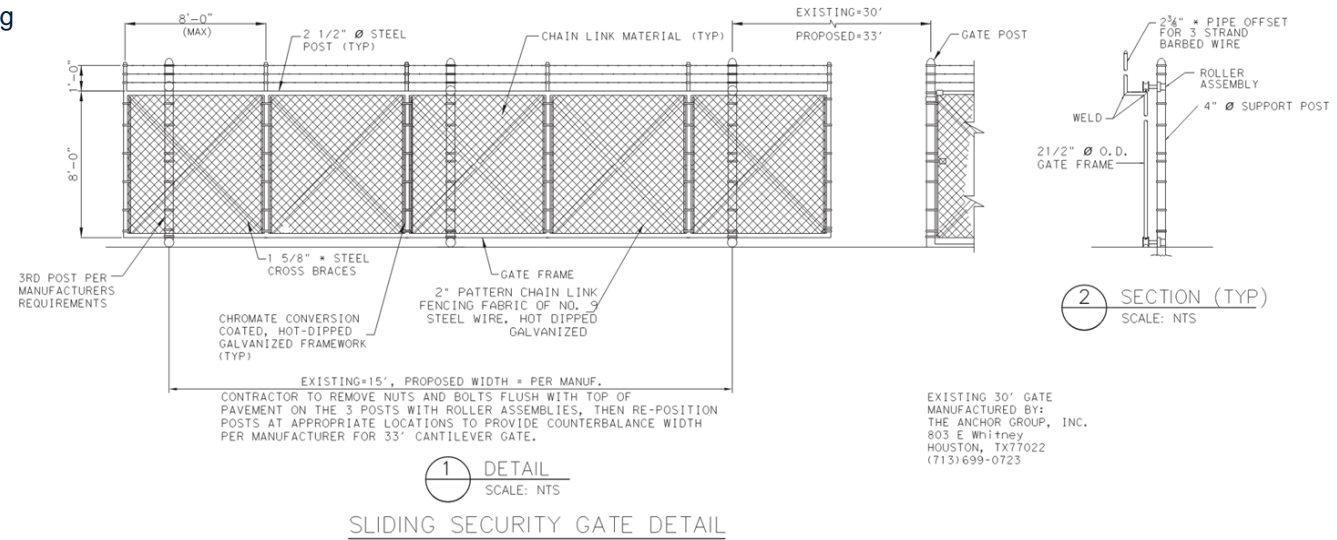

NOTES:

1. CONTRACTOR TO REMOVE AND DISPOSE OF EXISTING 30' CANTILEVER GATE AND REPLACE WITH NEW 33' CANTILEVER GATE.
2. CONTRACTOR TO REMOVE AND RELOCATE 3 EXISTING POSTS WITH ROLLER ASSEMBLIES TO ACCOUNT FOR 33' OPENING AND SPACING TO MEET MANUFACTURER'S COUNTERBALANCE WIDTH, AND RECONNECT EXISTING CHAINLINK FENCING TO THE POSTS.



PORT HOUSTON

Additional Details

DESCRIPTION	RUN NUMBER	ELECTRICAL SCHEDULE TABLE					
		1	2	3	4	5	6
CONDUCTOR	1 #6 BARE	1	1	1	1	1	1
SIGNAL CABLE	TRAF SIG CBL (TY A) (12 AWG) (7 CONDR)	2	2	3	5	2	5
DOME CAMERA	R-59 COAX CABLE (W16 / 3C)					1	
CONDUIT	2" (PVC)	1		1		1	
	2" (PVC) (BORE)		1				1
	3" (PVC) (BORE)						1
	3" (PVC)						1

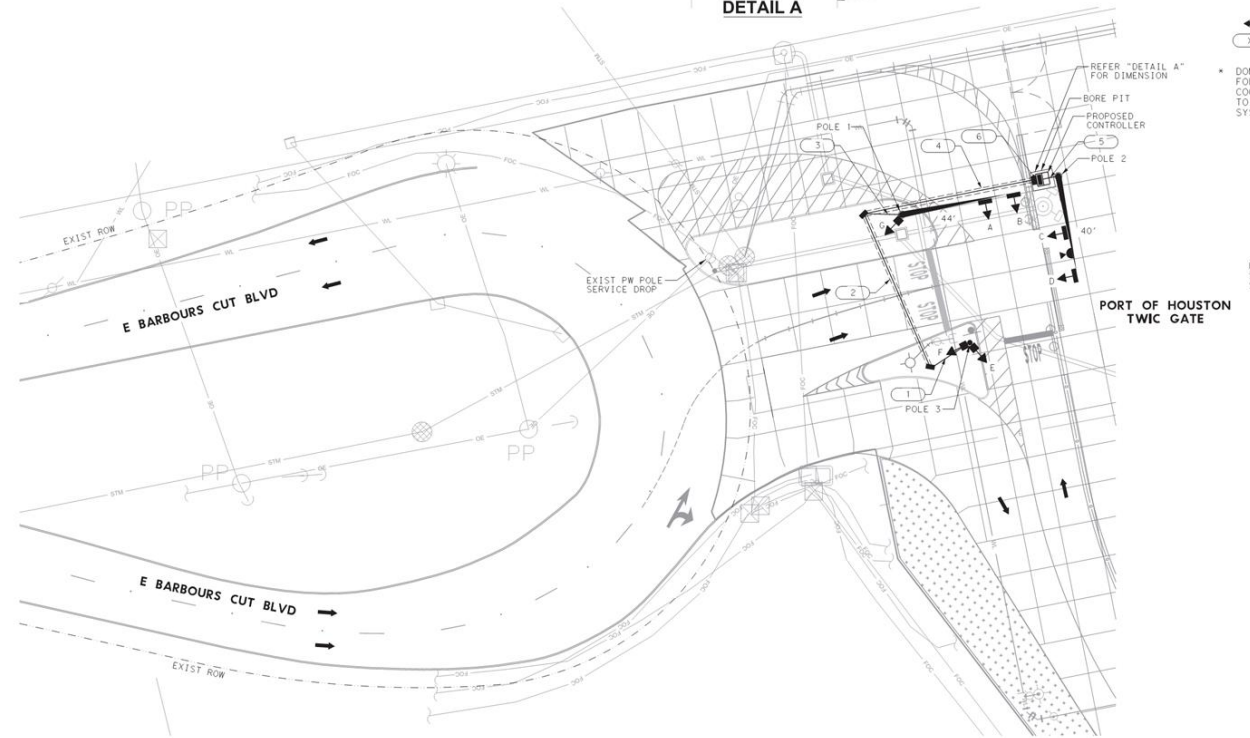
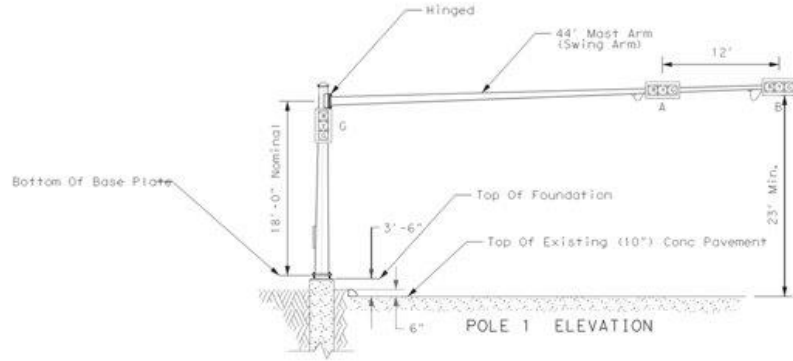
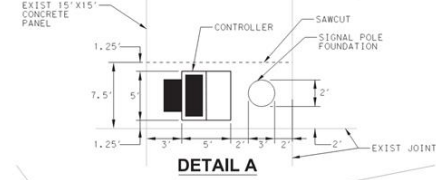

DESCRIPTION	PND TYP / DRILL SHAFT	S	W
POLE 1 INS TRF SIG PL AM(S) 1 ARM (44') (HINGED ARM)	36 B / 27"	2042.58	2956.46
POLE 2 INS TRF SIG PL AM(S) 1 ARM (40') (HINGED ARM)	36 B / 27"	2039.44	2891.61
POLE 3 PED POLE ASSEMBLY (20')	24 A / 8"	2096.44	2939.5

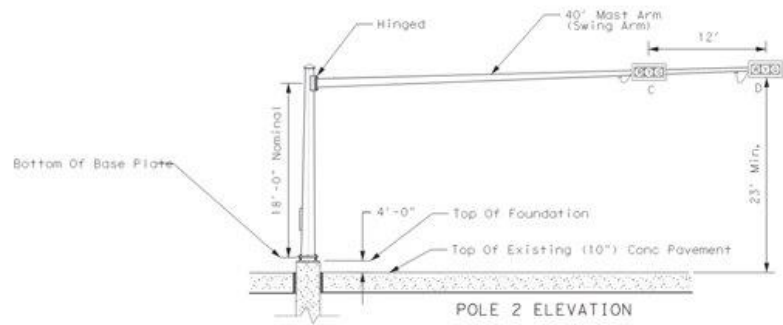

- LEGEND (PROPOSED)**
- MAST ARM POLE (SWING TYPE)
 - ◄ HORIZONTAL SIGNAL HEAD
 - ◄ VERTICAL SIGNAL HEAD
 - ◄ VERTICAL SIGNAL HEAD
 - ◄ DOME CAMERA (DETECTION)
 - ◄ GROUND BOX
 - ◄ GROUND MOUNTED CONTROLLER CABINET W/APRON
 - CONDUIT (TRENCH)
 - CONDUIT (BORE)
 - ◄ PROP SMALL SIGN
 - ◄ TRAFFIC FLOW
 - ◄ X CABLE RUN

* DOME CAMERA EQUIPMENT IS SHOWN FOR DIAGRAMMATICAL PURPOSES ONLY. COORDINATE WITH EXISTING VENDOR TO PROVIDE COMPLETE DETECTION SYSTEM.

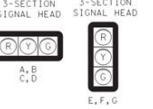

NOTE: SEE SHEET C-321 FOR TRAFFIC SIGNAL TIMING

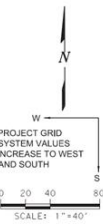

SITE VISIT

- Date: Monday, June 3, 2024
- Time: 1:00 PM
- Address: Barbours Cut Terminal Adm. Bldg., Large Conf. Rm.
1819 East Barbours Cut Blvd.
La Porte, TX 77571
- **PROPER PPE & ID REQUIRED, PREFERABLY TWIC**



QUESTIONS?

Procurement Services

Email: procurement@porthouston.com

Phone: (713) 670- 2464

New BuySpeed URL:

<https://buyspeed.porthouston.com>



PORT HOUSTON