

Pre-Proposal Conference:

CSP-2500 REPAIR OF INFRASTRUCTURE ALONG WHARF 18 DREDGE PIPE AT TURNING BASIN TERMINAL

November 29, 2022

9:30 a.m.

PORT HOUSTON



PORT HOUSTON

AGENDA

1. Pre-Proposal Conference House Rules
2. Introductions
3. Business Equity
4. Procurement Services
5. Selection Criteria
6. Project Scope
7. Questions



PRE-PROPOSAL CONFERENCE HOUSE RULES

- Attendees will begin the meeting in listen-only mode.
- There will be a Q&A session at the end of today's presentation.
- If you have any questions during the presentation, you may submit your Questions through the WebEx Q&A feature and they will be addressed at the end of the presentation.
- This presentation recording will be posted on the BuySpeed homepage under "Pre-Bid/Proposal Conference Information."



PHA Personnel:

Roger H. Hoh, P.E. – Director, PCM

Corrie Yaw – Project Manager

Ruth Flores – Construction Manager

Yvette Camel-Smith – Director, Procurement

Tanika Chukwumerije – Procurement Contract Manager

Brenda Ruiz – Business Equity

Eduardo Mejia – Business Equity

Non-PHA Personnel:

Robert Rocha – Harris County Wage Rate Monitor



PORT COMMISSION



Ric Campo
Chairman of the Port Commission



Dean E. Corgey
Commissioner



Clyde Fitzgerald
Commissioner



Stephen H. DonCarlos
Commissioner



Roy D. Mease
Commissioner



Wendy Montoya Cloonan
Commissioner



Cheryl D. Creuzot
Commissioner



PORT HOUSTON

Harris County Wage Rate Compliance & Requirements:

- Attendance at pre-bid/proposal meetings and preliminary meetings
- Review and approve weekly certified payroll records
- Monitor wage rate compliance
- Review claims of non-compliance from the field and recommend appropriate responses as required or permitted under the Wage Scale Act



BUSINESS EQUITY



PORT HOUSTON

BUSINESS EQUITY S/MWBE INITIATIVE

- Business Equity Division provides resources to small, minority- and woman-owned businesses (S/MWBE) seeking to participate in Port Houston procurements and contracts.
- Port Houston promotes business opportunities for all sectors of the community and recognizes the importance of vendor and supplier diversity in its contracts.
- Port Houston has established an organizational 35% Small Business participation goal and a 30% Minority- and Woman Business Enterprise (MWBE) aspirational goal.

35%

SBE participation
goal

30%

MWBE aspirational
goal



PORT HOUSTON

BUSINESS EQUITY

All dollars awarded and committed to enrolled S/MWBEs count towards Port Houston's S/MWBE goals regardless of whether the individual solicitation includes criteria for small, minority, woman-owned business participation.



PORT HOUSTON

BUSINESS ENTERPRISE DEFINITIONS

Small Business Enterprise (SBE)

- Gross revenues or number of employees, averaged over the past three years does not exceed the size standards defined by SBA.
- The net worth of the owner must be less than \$1.32 million, excluding the owner's primary residence and assets of the business.

• **Minority Business Enterprise (MBE)**

- At least 51% Owned by one or more Minority Individuals, or at least 51% of the equity is Owned by one or more Minority Individuals.
- Both the management and daily business operations are carried out and controlled by one or more of the Minority Individuals who own it.

Woman-Owned Business Enterprise (WBE)-

- At least 51% Owned by one or more Women, or at least 51% of the equity is Owned by one or more Women
- Both the management and daily business operations are carried out and controlled by one or more of the Women who own it.



CERTIFYING PARTNERS

Small and M/WBEs must meet certain criteria and be certified with one of the following partner agencies:

- City of Houston *
- Houston Minority Supplier Development Council
- METRO *
- National Minority Supplier Development Council & Affiliate
- Small Business Administration 8(a) *
- South Central Texas Regional Certification Agency – SCTRCA *
- Texas Comptroller of Public Accounts – HUB Certification
- Texas Department of Transportation – TxDOT *
- Women’s Business Enterprise Alliance
- Women’s Business Enterprise National Council & Affiliates – WBENC

* No fee to apply



Local Presence

- Harris
- Montgomery
- Waller
- Ft. Bend
- Brazoria
- Galveston
- Chambers
- Liberty



PORT HOUSTON S/MWBE ENROLLMENT DIRECTORY

How do I identify Port Houston enrolled small, minority- and woman-owned businesses (S/MWBE)?

Search for businesses in 2 easy steps:

1. Visit <https://porthouston.smwbe.com>

Under the section on the left labeled Small, Minority and Woman Owned Business

Directory and Online Application select the blue button labeled, "Find a S/MWBE Firm".

2. You will need to complete at least one of the fields in the popup window titled, Port Houston S/MWBE Enrollment Directory and Search.

<https://porthouston.smwbe.com/Default.asp?>



[OUR MAIN SITE](#)

[CONTACTS AND SUPPORT](#)



SMALL, MINORITY AND WOMAN OWNED BUSINESS DIRECTORY AND ONLINE APPLICATION

Search for small, minority, and woman-owned businesses enrolled in Port Houston's Business Equity Programs, and/or apply to become an enrolled small, minority or woman-owned business.



[Find a SMWBE Firm](#)

OUTREACH & PROGRAM NOTICES

Business Networking Events

[Detailed Description](#)

[RSVP For An Event](#)

SYSTEM TRAINING

www.porthouston.smwbe.com



PORT HOUSTON

BUSINESS EQUITY CONTRACT REQUIREMENTS

- 15% Small Business Enterprise (SBE) participation, 5 points relative weight



TIPS TO INCREASE PARTICIPATION

- Establish relationships with S/MWBE's in advance
- Assuring that S/MWBEs are solicited whenever they are potential sources;
- Subdivide the work, when economically feasible, into smaller tasks or quantities to permit maximum participation by S/MWBE's;
- Use the Port of Houston Directory.
- Advertise opportunities
- Offer assistance and use the services and assistance, as appropriate, of such organizations as the Small Business Administration and the Minority Business Development Agency of the Department of Commerce.
- What subcontractors have you done business in the past and do they qualify?



PROCUREMENT



PORT HOUSTON

PROCUREMENT

- No Contact Period – No communication between interested vendors and Port Houston staff during the active period.
 - Technical questions should be submitted via BuySpeed
 - Last day to submit questions: 7 days before due date (12/7/2022)
- Responses are due no later than 11 a.m. on 12/14/2022
- Proposals must be submitted electronically via email to: procurementproposals@porthouston.com
- Use forms in the package
- Anticipated award date: 1/24/2023



EVALUATION CRITERIA

Port Houston will select the provider of the services offering the **best value** to Port Houston. The response package will be evaluated based on the following criteria and relative weights.

Evaluation Criteria	Relative Weight (%)
Price	40
Vendor's Reputation, Quality of Services and Safety Record	25
Benefit to Port Authority	25
Overall Compliance with Port Houston Policies	5
Small Business Participation	5



DOCUMENT CHECKLIST

Proposal Response form:
(Page 31 of Solicitation Package)

Page 2 of the Proposal Response
Form – Required Attachments



PORT OF HOUSTON AUTHORITY Proposal Response

PURCHASE OF THREE DOCKSIDE ELECTRIC CONTAINER CRANES FOR WHARVES NOS. 2 AND 6 AT BAYPORT CONTAINER TERMINAL

For detailed instructions regarding the completion of this Proposal Response form and other related forms, or the submission, evaluation, or ranking of proposals or bids, see Instructions to Respondents.

If Respondent Company Business Entity is privately held, please list all equity owners and their contact information: <i>(If not enough room, list on separate sheet)</i>	Name	Address	Telephone

Part C: Response Attachments

Complete and attach the following required documents to the Proposal Response in the order listed below. All required attachments are due to be submitted as one package by the Response Due Date. Regardless of delivery method or circumstance, any Response received after the specified time and date will be returned to the Respondent unopened. Any Response submitted using forms other than those provided by PHA, when such forms are provided, or excluding any of the documentation requested, may be rejected by PHA.

Attach to Response	Attachment No.	Attachment Name ^[1]
<input checked="" type="checkbox"/>	Attachment 01	Price Form, including Price Exhibit
<input checked="" type="checkbox"/>	Attachment 02	Services Experience Form
<input checked="" type="checkbox"/>	Attachment 03	Professional References Form
<input checked="" type="checkbox"/>	Attachment 04	Background Information Form
<input checked="" type="checkbox"/>	Attachment 05	Additional Response Submittals – High Tech Equipment*
<input checked="" type="checkbox"/>	Attachment 06	Disclosure of Former Port Authority Employees Form
<input checked="" type="checkbox"/>	Attachment 07	Work Breakdown Form
<input checked="" type="checkbox"/>	Attachment 08	Small, Minority-and Women-Owned Business Enterprise Plan
<input checked="" type="checkbox"/>	Attachment 09	Small, Minority-and Women-Owned Business Enterprise Participation Letter of Intent
<input type="checkbox"/>	Attachment 10	NOT USED
<input checked="" type="checkbox"/>	Attachment 11	Safety Record Data Form
<input checked="" type="checkbox"/>	Attachment 12	Conflict of Interest Questionnaire
<input checked="" type="checkbox"/>		Port of Houston Authority Bid/Proposal Security Form
		Other _____

[1]: Except where noted otherwise by **, each attachment submitted must be on the Port of Houston Authority form included in the proposal documents.

SCOPE OF WORK OVERVIEW



PORT HOUSTON

Overall Project Scope

- Project Includes
 - Installation of 110 LF of 36" Steel Casing By Micro tunneling
 - Repair of Intrusion in 30" Steel Casing By Open-Cut
- Project Duration: 155 Calendar Days
- Milestone Attached to Intrusion Repair
 - Separate Notice to Proceed
 - 5 Calendar Day Duration from NTP
 - Liquidated Damages: \$9,280.00/day after 5 calendar days

36" Steel Casing Install



30" Steel Casing Repair



Trenchless Crossing

- Location – North of Clinton Drive; Under PTRA railroad tracks
- Installation of 110 LF of 36" Steel Casing by Micro tunneling
- Work to be conducted solely by the contractor PHA awards

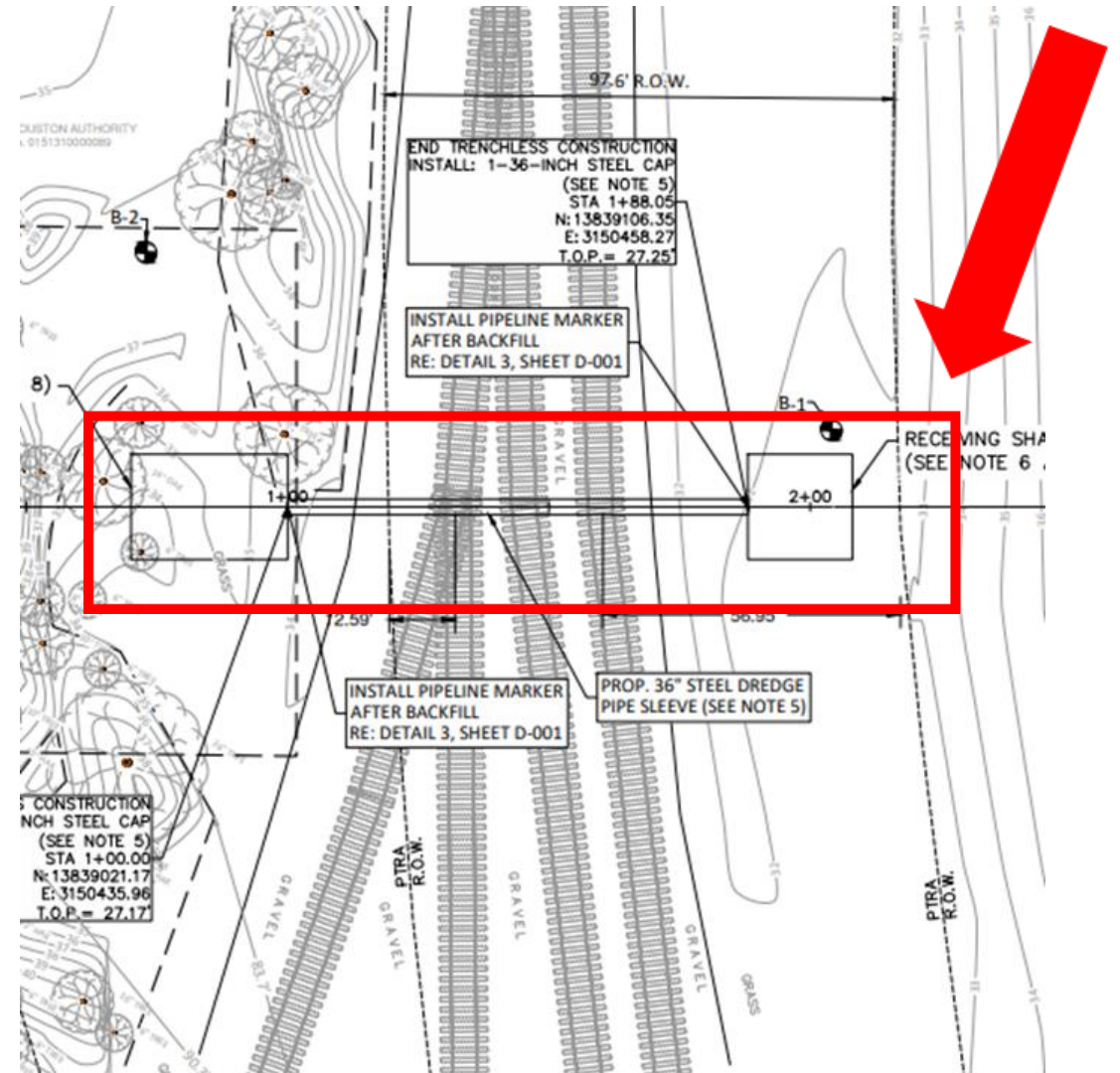

Open-Cut Repair Inside PTRA

Yard

- Location: Under railroad tracks 6-8 inside PTRA's railyard
- Removal and replacement of 10 LF of 30" steel casing by open-cut
- Intrusion repair must be conducted within 7 days or liquidated damages will be imposed
- Work to be split between PTRA maintenance crew and contractor hired by PHA:
 - PTRA
 - (1 day) Remove rail ties and all ballast/sub-ballast to top of sleeve
 - (1 day) Backfill/compact all ballast/sub-ballast and replace rail ties once fix is complete
 - PHA
 - (5 days) Excavate around steel casing, install shoring, complete the inclusion repair, backfill with flowable fill to the top of casing

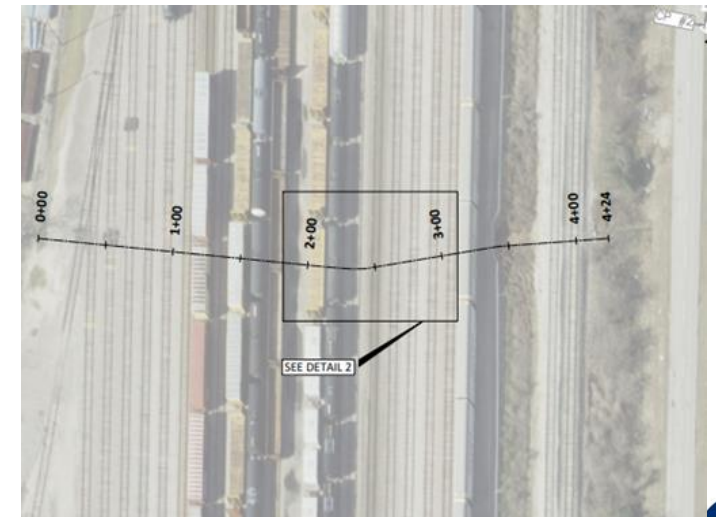
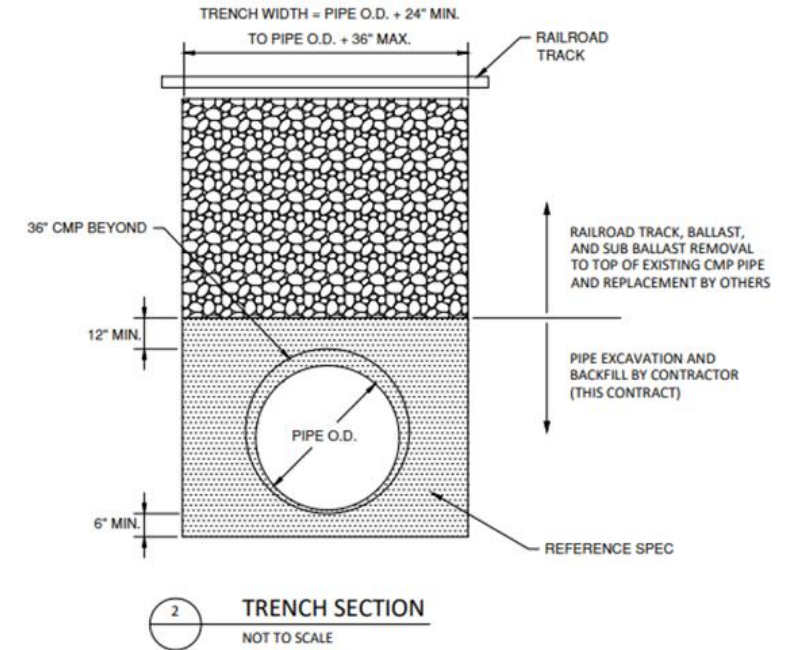

Site Coordination

- Stockpiles and materials to be confined to laydown areas specified on plan drawings
- Excess fill to be disposed of by Contractor
- 20-day minimum notice to PHA before hauling
- Stockpiled material to be tested by PHA prior to hauling
- Contractor to coordinate with PTRRA for railroad flaggers
- TWIC card not needed for project site



Project Specific Requirements

- 20% SBE Goal
- By submitting proposal
 - Agree to 60-day NTP and mobilization from award date
- Major Submittals Prior to Mobilization Include/Not Limited to:
 - Dust Control Plan
 - Health and Safety Plan
 - Storm Water Pollution Prevention Plan (SWP3) Package
 - Noise Control Plan
 - Construction Site Dewatering Plan



Project Site Visit

- Today, 11/29 at **1:30 pm**
- Address:
8515 Clinton Drive, Houston, Texas 77029
- TWIC or a current State ID is required
- Hi-vis vests and hard hats required
- Please limit to 2 personnel (very limited parking at 8515 Clinton Dr.)



Procurement Services

Email: procurement@porthouston.com

Phone: (713) 670- 2464

QUESTIONS?

PORT HOUSTON



PORT HOUSTON